



ABO valve

ABsOlute flow control

SERIES 900

- // PN 16 / Class 150
- // DN 32 - 1600 (1" ¼ - 64")
- // Industrial applications
- // Water, chemicals, gas
- // Oil & gas, air

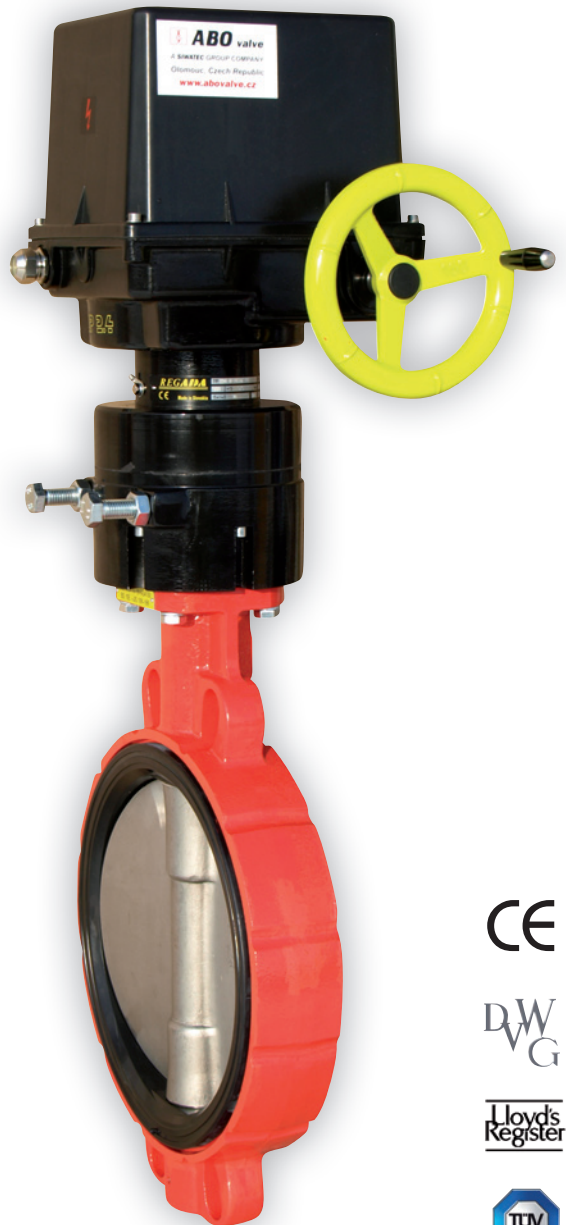

CE

DWVG

Lloyds Register



INTERFLANGES BUTTERFLY VALVES

WWW.ABOVALVE.COM

GENERAL INFORMATION, MATERIALS

BUTTERFLY VALVES SERIES 900 ARE MANUFACTURED IN DN 32 ÷ DN 1600.

TYPE DESIGNATION:

9 2 4 B

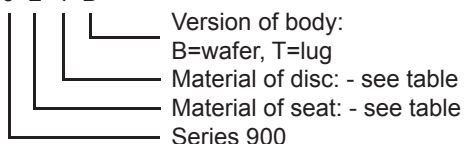

MAX. WORKING PRESSURE	
DN 32 ÷ 600	DN 700 ÷ 1600
16 bar	10 bar*

*16 bar upon request

Note: When temperature of medium increases over + 120 °C, the max allowed pressure falls from 16 bar to 14,4 bar and from 10 bar to 9 bar.

GENERAL APPLICATIONS:

Butterfly valves series 900 are suited for many applications where tight shut-off is required, such as:

- Industrial Processing
- Dry Bulk Conveying
- Paper Mills
- HVAC (Heating, Ventilating & Air Conditioning)
- Water and Wastewater
- Light Slurry Handling
- Food and Beverage

LEAK TEST:

- EN 12266-1, CLASS A (SUBSTITUTES DIN 3230 - LEAK 1)
- ISO 5208, CLASS A
- API 598, TABLE 5

TOP FLANGE:

- EN ISO 5211

CONNECTION BETWEEN FLANGES:

- EN 1092-1
- DIN 2631

FACE TO FACE ACC.:

- EN 558, SERIES 20
- ISO 5752, SERIES 20
- API 609

WORKING STANDARD:

- EN 593 + A1

INSTALLATION BETWEEN FLANGES (DN 32-600)

Vers.		32/40	50	65	80	100	125	150	200	250	300	350	400	450	500	600
B	PN 6											•	•	•	•	•
	PN10															
	PN16													•	•	•
	Class 150															
T	PN 6	•	•	•	•	•	•	•	•	•	•	•	•	•	•	•
	PN10															
	PN16															
	Class 150	•	•	•	•	•	•	•	•	•	•	•	•	•	•	•

standard

upon request

*For JIS 5K/10K, please consult with manufacturer.

DEMOUNTABLE VERSION DN 32 ÷ DN 1600

Marking: 900B - wafer type / 900T - lug type

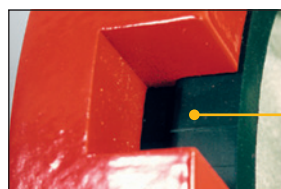

Seat is anchored in body

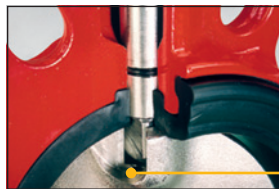

Movement of disc ensured by four-squared endstem

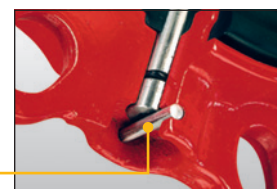

Pivot fixed by pin allows demounting

MATERIALS

While selecting the material of disc and seat for concrete working conditions, it is recommended to consult it with the manufacturer. Execution in other material types can be provided upon request.

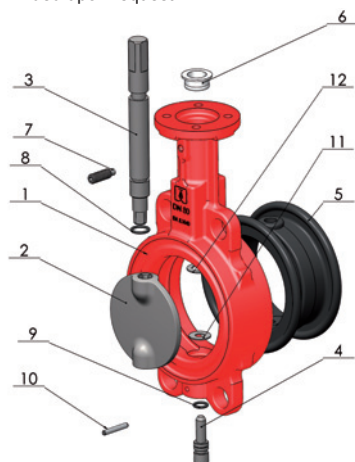

POS.	MATERIAL SPECIFICATION	
1	Body	Ductile iron 0.7040 (GGG40) epoxy coated Carbon steel 1.0619 (A216 WCB) Low carbon content steel 1.1156 (A352 LCC) Stainless steel 1.4408 (CF8M)
2	Disc	See table
3	Stem	Stainless steel
4	Pivot	Stainless steel
5	Seat	See table
6	Bushing	Brass or Delrin
7	Lock washer	Zinc coated steel or stainless steel
8	Stem O-ring	NBR
9	Pivot O-ring	NBR
10	Pin	Zinc coated steel or stainless steel
11	Pivot washer	Stainless steel
12	Stem washer	Stainless steel

MATERIALS OF SEAT AND DISC

SEAT	1	NBR - 10°C + 100°C
	2	EPDM - 25°C + 125°C
	3	Carboxylic NBR - 15°C + 60°C
	4	VITON (FPM) - 25°C + 150°C
	5	Silicone Steam - 25°C + 140°C
	6	Silicone (UMQ) - 25°C + 150°C
	7	Epichlorohydrin - 25°C + 70°C
	8	HYPALON® (CSM) - 15°C + 120°C
DISC	0	Brass 2.0402
	1	Aluminium bronze 2.0966
	2	Stainless steel 1.4308 (CF8)
	3	Ductile iron 0.7040 (GGG40)
	4	Stainless steel 1.4408 (CF8M), HALAR coating is as option
	5	HASTELLOY
	6	URANUS B6
7	Titanium	

Choice of the seat and disc materials for various media will be recommended upon specific enquiry. The above mentioned max. temperatures for each material of seat are accepted only for a specific medium and short time. Please always consult seat material selection with the manufacturer.

DIMENSIONS DN 32-600 (1"¼ - 24")

Lug type T

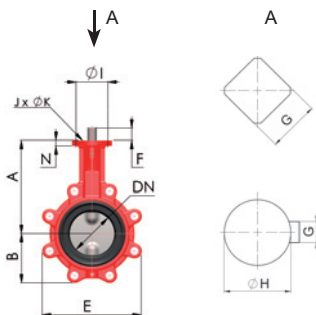

Wafer type B

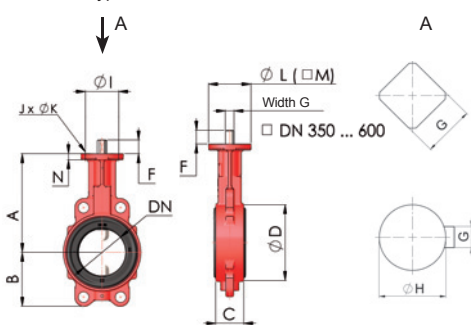

DN	mm																					
	32	40	50	65	80	100	125	150	200	250	300	350	400	450	500	600						
	inch 1"¼ 1"½ 2" 2"½ 3" 4" 5" 6" 8" 10" 12" 14" 16" 18" 20" 24"																					
Version	B	A	136	136	146	153,5	163	172,5	192,5	205	234	270	310	325	365	375	482	562				
	T	A	136	136	146	153,5	163	172,5	192,5	205	234	270	310	325	365	375	485	565				
Valve dimensions	B	54	54	64	72	89	100	118	128	166	202	237	271	314	330	363	464					
	C	33	33	43	46	46	52	56	56	60	68	78	78	102	114	127	154					
	D	78	78	96	113	128	150	184	212	268	320	378	432	483	521	590	695					
	E	110	110	116	131	173	192	235	258	325	397	464	505	587	633	704	836					
	F	25	25	25	25	25	25	25	25	25	30	30	36	36	80	80	80					
Endshaft dimensions	G	14						17			22		27		12		12		14			
	H	-	-	-	-	-	-	-	-	-	-	-	-	-	Ø38	Ø42	Ø50					
	I	50						70			102		102		125		140		140	165		
ISO TOP Flange	J	4																				
	K	7						9			10,5		10,5		14		18		18		18	23
	L	-	-	-	-	-	-	-	-	-	-	-	-	-	-	-	175	175	210			
Flange dimensions	M	70	70	-	-	-	-	75	75	75	105	105	130	140	-	-	-	-				
	N	8	8	8	8	8	8	9,5	9,5	14	17	17	21	22	25	25						
	Weight	Type B	1,9	1,9	2,7	3,2	3,7	4,7	6,7	8,4	13,3	22,0	29,3	46,4	69,8	83,0	112	216				
	Type T	2,3	2,3	3,0	3,7	4,8	6,1	9,2	10,2	15,3	28,4	41,2	62	96,3	130	149	288					
ISO Flange		F05 / F07						F07			F10		F12		F14		F16					

Dimensions mentioned in mm, weight in kg.

¹ For PN 10 308 mm

For the valves DN32/40 the flange conforms to F05 and also F07, for the valves DN 32 - 200 DN50-100 the standard flange is F05, flange F07 can be provided upon request.

OPERATING TORQUES UPON WORKING PRESSURE (NM)*

DN	32/40	50	65	80	100	125	150	200	250	300	350	400	450	500	600
PMA 6 bar	6	8	15	20	38	55	70	100	150	235	480	750	1180	1380	2050
PMA 10 bar	8	10	17	25	46	70	80	125	220	290	530	1200	1550	2050	2700
PMA 16 bar	10	12	20	30	55	85	100	150	290	380	580	1650	2100	2700	3750

The above mentioned torques are valid for valves with EPDM seat only, and under the condition that the working medium is liquid. While actuating the valve, the above mentioned figures should be multiplied by a coefficient of 1,2. Using a NBR seat, it is necessary to apply a coefficient of 1,8 for dimensions up to DN 300 and a coefficient of 1,32 for dimensions DN 350 and above. In case the medium is gaseous, or if it contains abrasive particles, it is necessary to apply a secondary coefficient of 1,35. If the working conditions are specific, it is recommended to discuss the selection of the actuator with the manufacturer.

MANUAL ACTUATION: HANDLEVER

DN 32 - 200

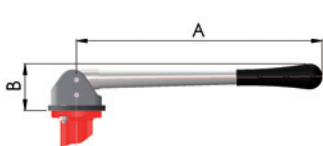

DN 250 - 300

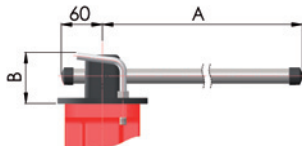

DN	32 - 100	125	150 - 200	250	300
A	240	290	362	450	750
B	75	80	90	135	135
Weight	1,24	1,26	1,4	2,2	3,1

Dimensions mentioned in mm, weight in kg.

Type L (only up to 6 bar)

MANUAL GEARBOX WITH HANDWHEEL

DN 32 ÷ 600

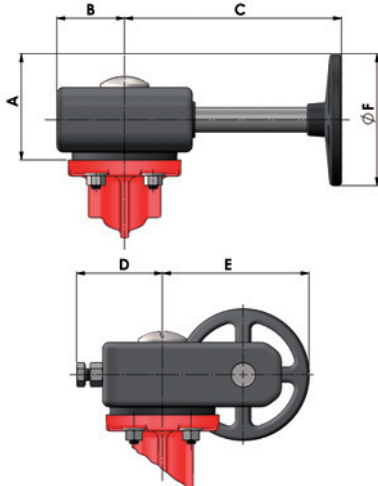

DN	32 - 150	200	250-300	350	400	450	500	600
A	89	89/127**	155	213	263	275	275	350
B	51	51	66	83	83	99	99	126
C	152	152/185**	272	302	334	279	279	366
D	44	44	59	70	70	86	86	114
E	101	101/138,5**	177	242	292	314	314	423
F	125	125/200*	250	350	450	450	450	600
Weight	1,6	1,6	3,7	6,6	6,6	14,5	14,5	27,2
Wheel	SR5	SR5/SR8*	SR10	R14	R18	R18	R18	R24

Dimensions mentioned in mm, weight in kg. Valid for SE Series (DN 32 - 400), M Series (DN 450 - 600).

*Optional

**Acc. to handwheel choice

Handlever and gearbox can be supplemented with contacts for signalisation of endpositions.

Other possibilities of actuation:

- Electric actuator 24V, 230V, 380V
- Pneumatic actuator (single/double acting)

Standard coating is orange epoxy painting RAL 2002 - 80 µm. According to customer's request, it is possible to modify the appearance of the colour of butterfly valves ABO.

DIMENSIONS DN 700 - 1600 (28" - 64") PN 10

DN	mm	700	800	900	1000	1200	1400	1600
	inch	28	32	36	40	48	56	64
Verion - Double flanged	A	629	666	720	800	940	1009	1150
Valve dimensions	B	537	601	656	720	844	1014	1045
	C	165	190	203	216	254	279	318
	D	840	950	1050	1160	1380	1590	1820
	E	95	95	130	130	150	150	180
End Shaft Dimensions	F	95	95	130	130	150	150	180
	G	16	16	20	22	28	32	40
	H	55	55	75	85	105	120	140
	M	63	63	84	95	117	134	178
ISO Top flange Dimensions	I	254	254	254	254	298	356	356
	J	8	8	8	8	8	8	8
	K	18	18	18	18	22	33	33
	L	300	300	300	300	350	415	415
Top flange		F25	F25	F25	F25	F30	F40	F40
Weight		350	580	700	850	1080	1922	2350

Dimensions mentioned in mm, weight in kg, PN 10. For version PN 16 / Class 150 upon request. Face to face acc. to DIN 3202 K1, ISO 5155, API 609, ISO 5752-20.

Operating torques for DN 700-1600

DN (mm)	Torque (Nm)
700	3500
800	4500
900	6000
1000	8950
1200	12600
1400	18500
1600	24400

The above mentioned torques are valid for valves with EPDM seat, water at +20°C, working pressure 10 bar.

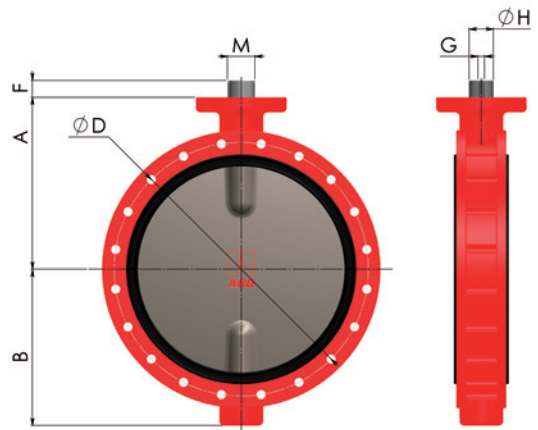
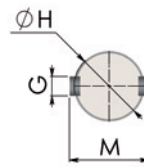
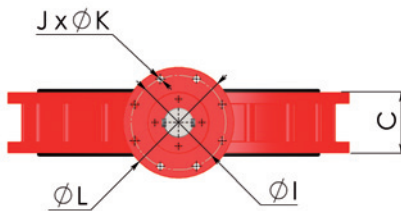

SERIES 900 FOR GAS

- **Range:** DN 32 (1" ¼) - DN 1600 (64")
- **Temperature range:** from - 25°C up to + 150°C
- **Maximum working pressure:** 16 bar (from DN 350 upon request)
- Gas Series is offered also in Series 600 (economic version)



EUROPEAN UNION
EUROPEAN REGIONAL DEVELOPMENT FUND
INVESTMENT IN YOUR FUTURE

The information in this brochure is indicative only. Binding specification will be provided in the offer. ABO valve accepts no liability for damages caused by bad interpretation or use of the information included in this brochure.

5. 2. 2013

Data subject to change.

Company HQ – Czech Republic:
ABO valve, s.r.o.
Dalimilova 285/54, 783 35 Olomouc
Tel: +420 585 202 226, +420 585 224 087
Email: export@abovalve.com
www.abovalve.com

Slovakia:
ABO Slovakia, s.r.o.
Banská Bystrica
Tel: +421 484 145 633
Email: aboslovakia@aboslovakia.sk
www.aboslovakia.sk

Russia:
ABO ARMATURA Ltd.
Smolensk
Tel: +7 4812 31 28 27
Email: aboarmatura@yandex.ru
www.aboarmatura.ru

Singapore:
ABO Singapore Pte. Ltd.
Singapore
Tel: +65 6383 4368
Email: lsw@abovalve.com
www.abovalve.com.sg

Brazil:
ABO Brasil
Simões Filho - Salvador
Tel: +55-71-8787-4599
Email: bernardo@abovalve.com
www.abovalve.com

China:
ABO China Representative
Wen XuYang
Tel: +86 13601522831
Email: wen@abovalve.com
www.abovalve.com